

PARTS MANUAL

UL SERIES ROTARY TILLER

R D PLATE ASSEMBLY (U-SERIES)

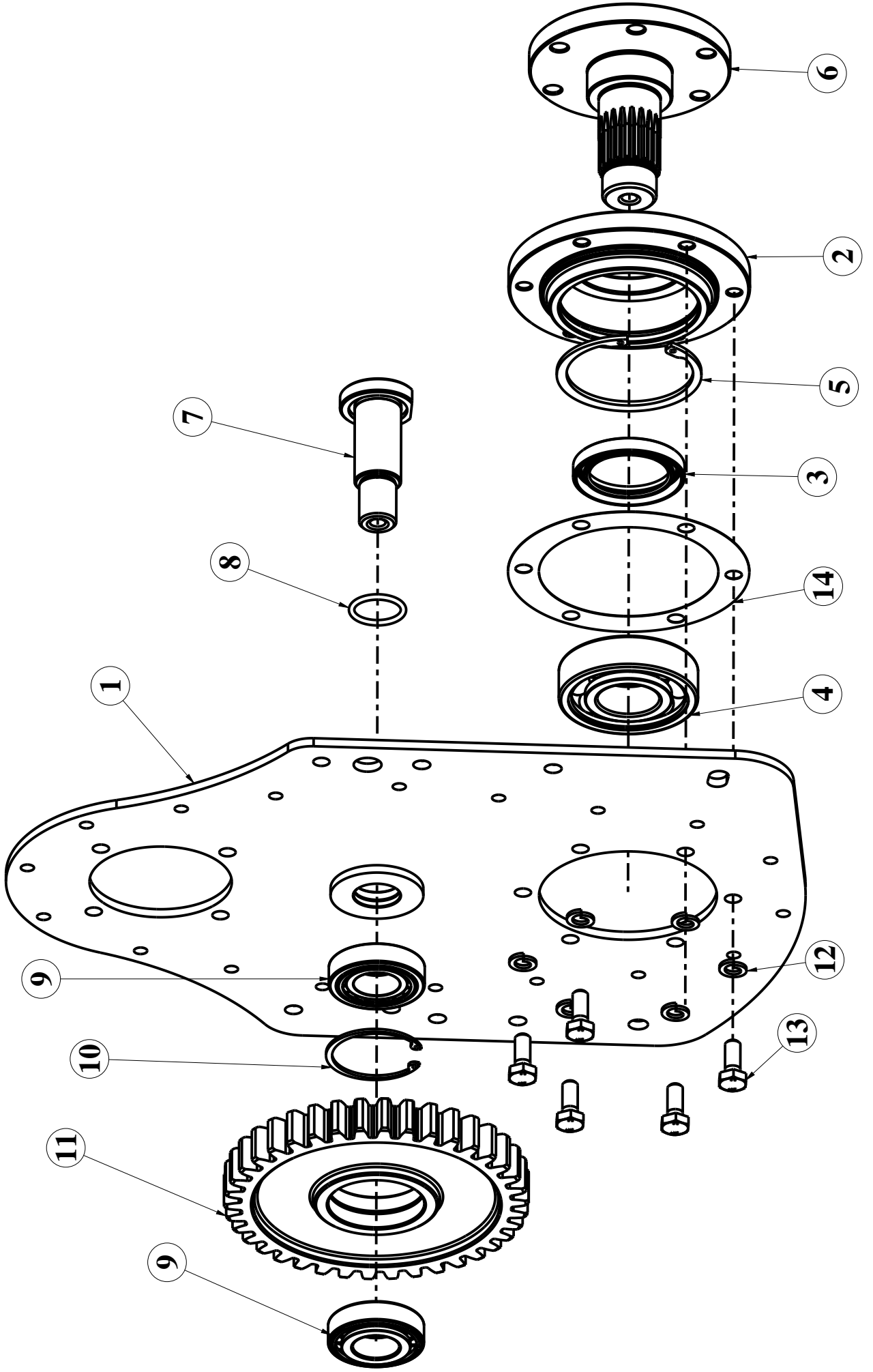

R D ASSEMBLY SPARE PARTS LIST

ITEM	P/NUMBER	QTY.	PART NAME
1	14320	1	R D PLATE GD COMP (U-SERIES)
2	14019	1	ROTOR SHAFT HOUSING (U-SERIES)
3	14051	1	OIL SEAL 55 X 72 X 10
4	8036	1	BEARING 6308
5	3027	1	CIRCLIP INTERNAL 90MM
6	14022	1	R D SHAFT (U-SERIES)
7	14025	1	R D SHAFT SMALL (U-SERIES)
8	14131	1	O RING 30 x 3.50
9	14055	2	BEARING 30206
10	8120	1	CIRCLIP INTERNAL 62MM
11	14033	1	GEAR 38 TEETH (U-SERIES)
12	1304	6	SPRING WASHER 10MM
13	17270	6	HEX BOLT M10 X 1.50 X 25 (8.8) DIN931
14	14018	1	S D PLATE END COVER GASKET (U-SERIES)

S D PLATE ASSEMBLY (U-SERIES)

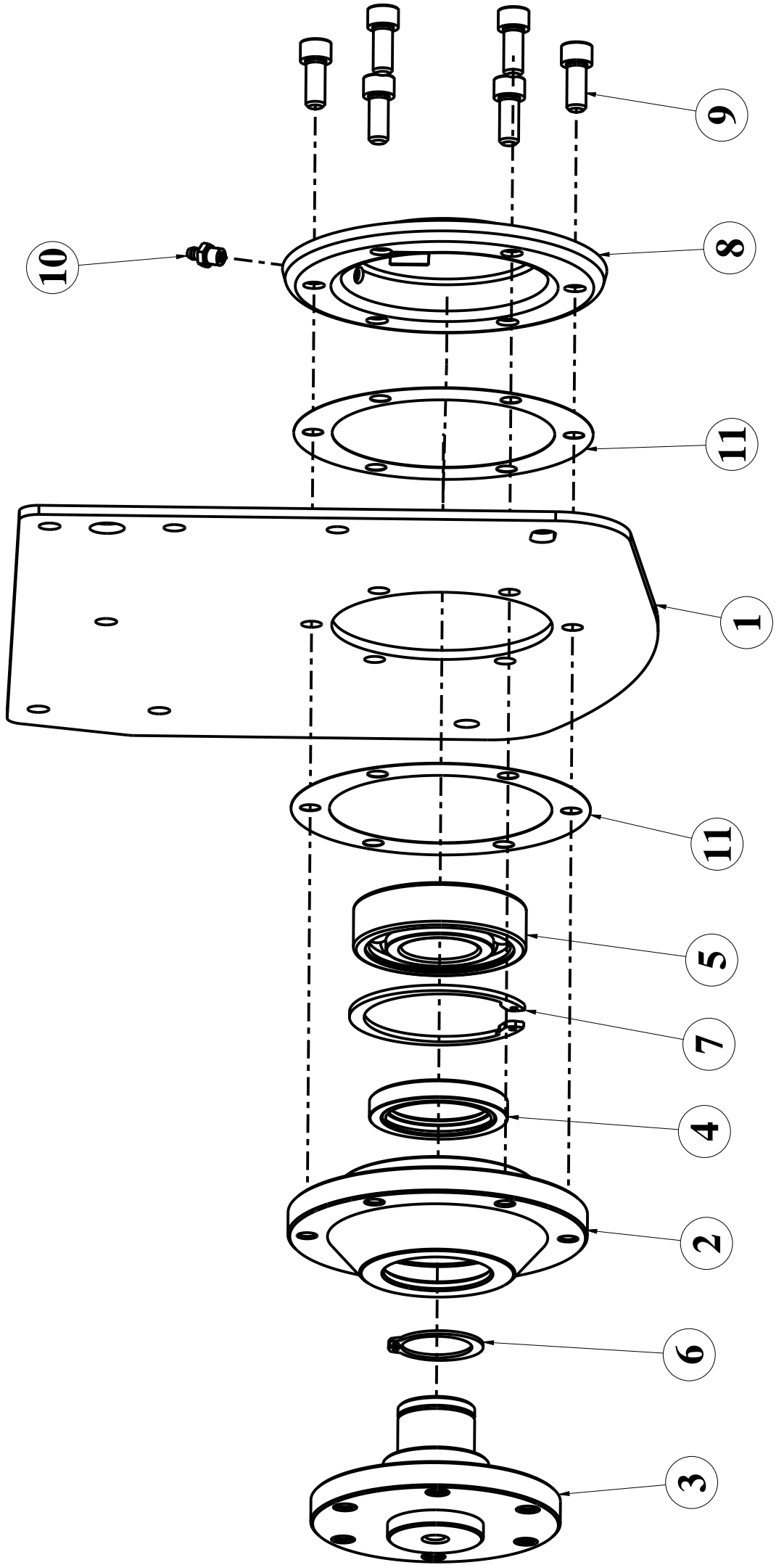

S D ASSEMBLY SPARE PARTS LIST

ITEM	P/NUMBER	QTY.	PART NAME
1	14023	1	S D PLATE (U-SERIES)
2	14019	1	ROTOR SHAFT HOUSING (U-SERIES)
3	14021	1	STUB AXLE SHAFT (U-SERIES)
4	14051	1	OIL SEAL 55 X 72 X 10
5	8036	1	BEARING 6308
6	8027	1	CIRCLIP EXTERNAL 40MM
7	3027	1	CIRCLIP INTERNAL 90MM
8	14256	1	SD PLATE END COVER COMP. (U-SERIES)
9	2833	6	ALLEN BOLT M10 X 1.50 X 25
10	1253	1	1/8 BSP GREASE NIPPLE 7.5MM
11	14018	2	S D PLATE END COVER GASKET (U-SERIES)

GEAR BOX ASSEMBLY (U-SERIES)

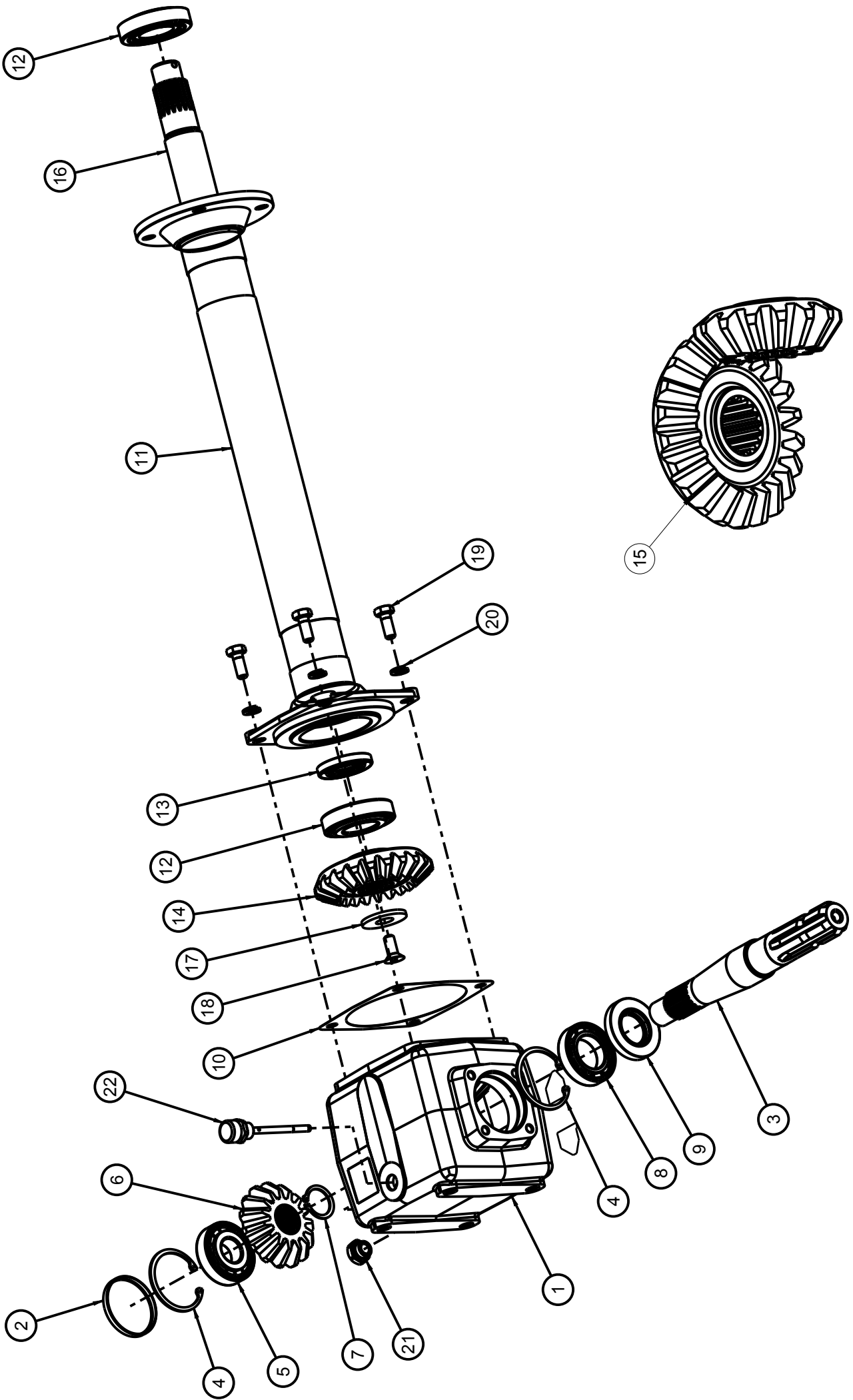

OPTIONAL SPARE PART

GEAR BOX ASSEMBLY SPARE PARTS LIST

ITEM	P/NUMBER	QTY.	PART NAME	Remarks
1	14043	1	GEAR BOX 540 RPM (U-SERIES)	
2	14075	1	OIL SEAL 62 X 7	
3	14046	1	INPUT SHAFT (U-SERIES)	
4	8120	2	CIRCLIP INTERNAL 62MM	
5	14053	1	BEARING 30305	
6	14047	1	PINION 15 TEETH (U-SERIES)	
7	11058	1	EXTERNAL CIRCLIP 30MM	
8	14054	1	BEARING 6007	
9	14057	1	OIL SEAL 35 X 62 X 10	
10	14044	1	JACK SHAFT HOUSING GASKET GD (U-SERIES)	
11	14269	1	JACK SHAFT HOU. COMP 639M CM (U-SERIES)	UL-48 (CM)
	14006	1	JACK SHAFT HOUSING COMP 1.5M (U-SERIES)	UL-60
	10199	1	JACK SHAFT HOUSING COMP 0.9M (U-SERIES)	UL-36
	10206	1	JACK SHAFT HOUSING COMP 1.2M (U-SERIES)	UL-48 (SS)
	10300	1	JACK SHAFT HOU. COMP 1.05M (U-SERIES)	UL-42
12	1003	2	BEARING 30207	
13	14056	1	OIL SEAL 35 X 55 X 8	
14	14048	1	CROWN 22 TEETH (U-SERIES)	
15	14368	1	CROWN T22,PINION T15 PAIR (U-SERIES)	OPTIONAL PART
16	14268	1	JACK SHAFT 639 mm CM(U-SERIES)	UL-48 (CM)
	14045	1	JACK SHAFT 791 mm (U-SERIES)	UL-60
	10205	1	JACK SHAFT 539 mm (U-SERIES)	UL-48 (SS)
	10301	1	JACK SHAFT 566 (U-SERIES)	UL-42
	10067	1	JACK SHAFT 486 mm (U-SERIES)	UL-36
17	14049	1	CROWN WASHER (U-SERIES)	
18	14058	1	CSK BOLT M10 X 1.5 X 25	
19	17270	4	HEX BOLT M10 X 1.50 X 25 (8.8) DIN931	
20	1304	4	SPRING WASHER 10MM	
21	14312	1	DRAIN CAP 3/8" BSP (1GTC02UW)	
22	14317	1	DIPSTICK 90MM (M16 X 1.5) (1MLSR203)	

MACHINE ASSEMBLY (U-SERIES)

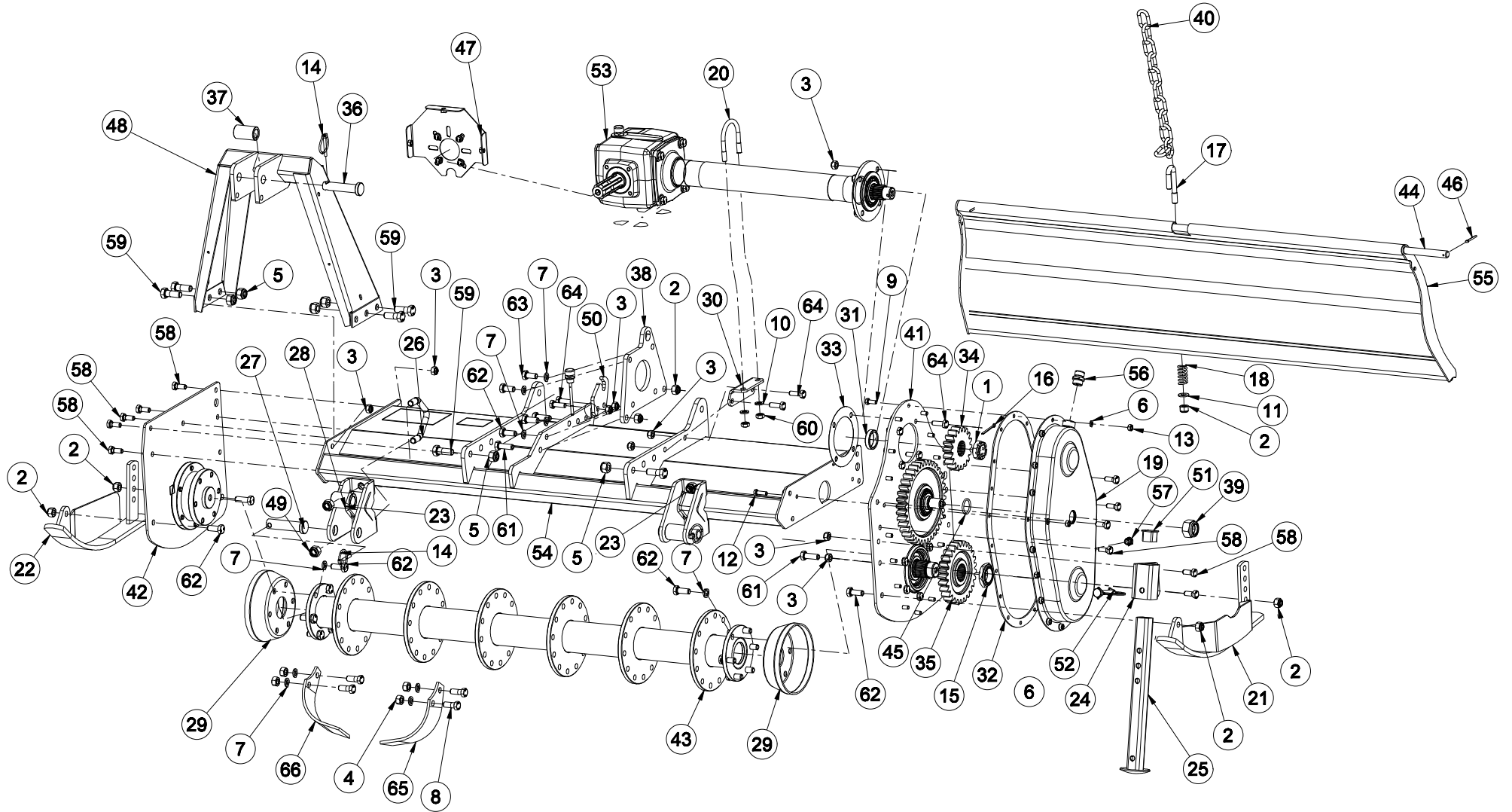

MACHINE ASSEMBLY SPARE PARTS LIST

ITEM	P/NUMBER	QTY.	PART NAME	REMARKS
1	8032	1	CASTLE NUT 28mm	
2	1209	7	NYLOCK NUT M12X1.75 (DIN-982)	
3	1298	19	NYLOCK NUT M10X1.50 (DIN-982)	
4	14336	48	HEX NUT M12 X 1.25 (10.9) DIN 934	For UL0.9
		60		For UL1.05
		72		For UL1.2
		84		For UL1.5
5	1302	6	NYLOCK NUT M14X1.50 (DIN-982)	
6	1303	18	SPRING WASHER 8mm	
7	14339	64	SPRING WASHER 12 MM ASME B18.21.1	For UL0.9
		76		For UL1.05
		88		For UL1.2
		100		For UL1.5
8	14324	48	HEX BOLT M12 X 1.25 X 30(HT-10.9)DIN 960	For UL0.9
		60		For UL1.05
		72		For UL1.2
		84		For UL1.5
9	8040	16	HEX BOLT M8 X 1.25 X 20	
10	8078	2	PLAIN WASHER 10mm	
11	8126	1	PLAIN WASHER 12mm	
12	8171	2	HEX BOLT M8 X 1.25 X 25	
13	8181	18	HEX NUT M8 X 1.25	
14	8204	3	LINCH PIN SMALL (CHO)	
15	1449	1	NYLOCK NUT M35X1.50	
16	14137	1	COTTER PIN (DIA 4 X 70)	
17	14004	1	J-BOLT M12 x 1.75 x 24 x 87.5 x 25TL	
18	14005	1	U-BOLT SPRING (U-SERIES)	
19	14007	1	CHAIN COVER GD COMP (U-SERIES)	
20	14008	1	U BOLT M10 X 1.5 X 71.00 X 90.00 X 24TL	
21	14009	1	DEPTH SKID COMP LH (U-SERIES)	
22	14010	1	DEPTH SKID COMP RH (U-SERIES)	
23	14011	2	M/C HITCHING BRACKET COMP (U-SERIES)	
24	14012	1	M/C MOUN STAND COMP (U-SERIES)	
25	14013	1	M/C STAND PIPE COMP (U-SERIES)	
26	14014	2	V-BOLT M14 x 2 x 90 x 83.2 x 26TL	
27	14015	2	HITCH PIN BOTTOM CAT-I (DIA-22 X 99)	
28	14016	2	BUSH (DIA. 36.5 X 22.5 X 50 L)	
29	14020	2	DUST COVER (U-SERIES)	
30	14027	1	JACK SHAFT HOUSING MOUN PLATE (U-SERIES)	
31	14029	1	SPACER DIA-45 x 35 x 9 MM	
32	14030	1	CHAIN COVER GASKET (U-SERIES)	
33	14031	1	JACK SHAFT HOUSING GASKET RD (U-SERIES)	
34	14032	1	GEAR 18 TEETH (U-SERIES)	
35	14034	1	GEAR 27 TEETH (U-SERIES)	
36	14037	1	HINCH PIN TOP CAT-I (DIA- 19 X 98)	
37	14038	1	BUSH (DIA. 19.5 X 31.5 X 52 L)	
38	14042	1	GEAR BOX MOUN PLATE (U-SERIES)	
39	14065	1	NYLOCK NUT M24X2.00 (DIN-982)	
40	14073	1	LIFTING CHAIN TB	
41	14077	1	R D PLATE ASSEMBLY (U-SERIES)	
42	14078	1	S D PLATE ASSEMBLY (U-SERIES)	

43	10209	1	ROTOR SRT-1.2M C/L-TYPE (U-SERIES)(60X6)	For UL1.2
	10202		ROTOR SRT-0.9M C/L-TYPE (U-SERIES)(60X6)	For UL0.9
	10298		ROTOR SRT-1.05M C/L-TYPE(U-SERIES)(60X6)	For UL1.05
	14002		ROTOR SRT-1.5M C/L-TYPE (U-SERIES)(60X6)	For UL1.5
44	10210	1	TRAILING BOARD ROD 1.2M (U-SERIES)	For UL1.2
	10203		TRAILING BOARD ROD 0.9M (U-SERIES)	For UL0.9
	10303		TRAILING BOARD ROD 1.05M (U-SERIES)	For UL1.05
	14050		TRAILING BOARD ROD 1.5M (U-SERIES)	For UL1.5
45	14131	1	O RING 30 x 3.50	
46	19018	2	COTTER PIN (DIA 4 X 35)	
47	14172	1	PTO SHAFT GUARD ASSEMBLY (SMALL)	
48	14239	1	TOP MAST COMP. (U-SERIES)	
49	1574	4	NYLOCK NUT M14X2.00 (DIN-982)	
50	14258	1	CHAIN LIFTING HOOK (U-SERIES)	
51	14266	1	SQ. PIPE PLASTIC CAP 32MM	
52	14267	1	SQ. SNAPPER PIN D10 X L70	
53	14270	1	GEAR BOX ASM. 540 RPM 639M CM(U-SERIES)	For UL1.2 (CM)
	10204		GEAR BOX ASSEMBLY 540 RPM 0.9M(U-SERIES)	For UL0.9
	10302		GEAR BOX ASM. 540 RPM 1.05M (U-SERIES)	For UL1.05
	10211		GEAR BOX ASSEMBLY 540 RPM 1.2M(U-SERIES)	For UL1.2 (S.S)
	14079		GEAR BOX ASSEMBLY 540 RPM 1.5M(U-SERIES)	For UL1.5
54	14271	1	HULL COMP 1.2M CM (U-SERIES)	For UL1.2 (CM)
	10200		HULL COMP 0.9M (U-SERIES)	For UL0.9
	10297		HULL COMP 1.05M (U-SERIES)	For UL1.05
	10207		HULL COMP 1.2M (U-SERIES)	For UL1.2 (S.S)
	14001		HULL COMP 1.5M (U-SERIES)	For UL1.5
55	14272	1	TRAILING BOARD COMP 1.2M CM (U-SERIES)	For UL1.2 (CM)
	10201		TRAILING BOARD COMP 0.9M (U-SERIES)	For UL0.9
	10299		TRAILING BOARD COMP 1.05M (U-SERIES)	For UL1.05
	10208		TRAILING BOARD COMP 1.2M (U-SERIES)	For UL1.2 (S.S)
	14003		T B COMP 1.5M (U-SERIES)	For UL1.5
56	14310	1	AIR BREATHER 1/2" BSP (1GTSR38)	
57	14313	1	OIL LEVEL GAUGE 1/4" BSP (1GTLN110)	
58	17270	11	HEX BOLT M10 X 1.50 X 25 (8.8) DIN931	
59	17271	6	HEX BOLT M14 X 1.50 X 37 (8.8) DIN931	
60	17272	2	HEX NUT M10 X 1.50 DIN 934	
61	17274	4	HEX BOLT M12 X 1.75 X 35 (8.8) DIN931	
62	17275	15	HEX BOLT M12 X 1.75 X 30 (8.8) DIN931	
63	17474	2	HEX BOLT M12 X 1.75 X 25(FT)(8.8) DIN933	
64	3340	8	HEX BOLT M10 X 1.50 X 30 (8.8) DIN933	
65	14041	12	BLADE C-TYPE LH (60X6)(157X117)	For UL0.9
		15		For UL1.05
		18		For UL1.2
		21		For UL1.5
66	14040	12	BLADE C-TYPE (60X6)(157X117)	For UL0.9
		15		For UL1.05
		18		For UL1.2
		21		For UL1.5

"CE" KIT ASSEMBLY (U-SERIES)

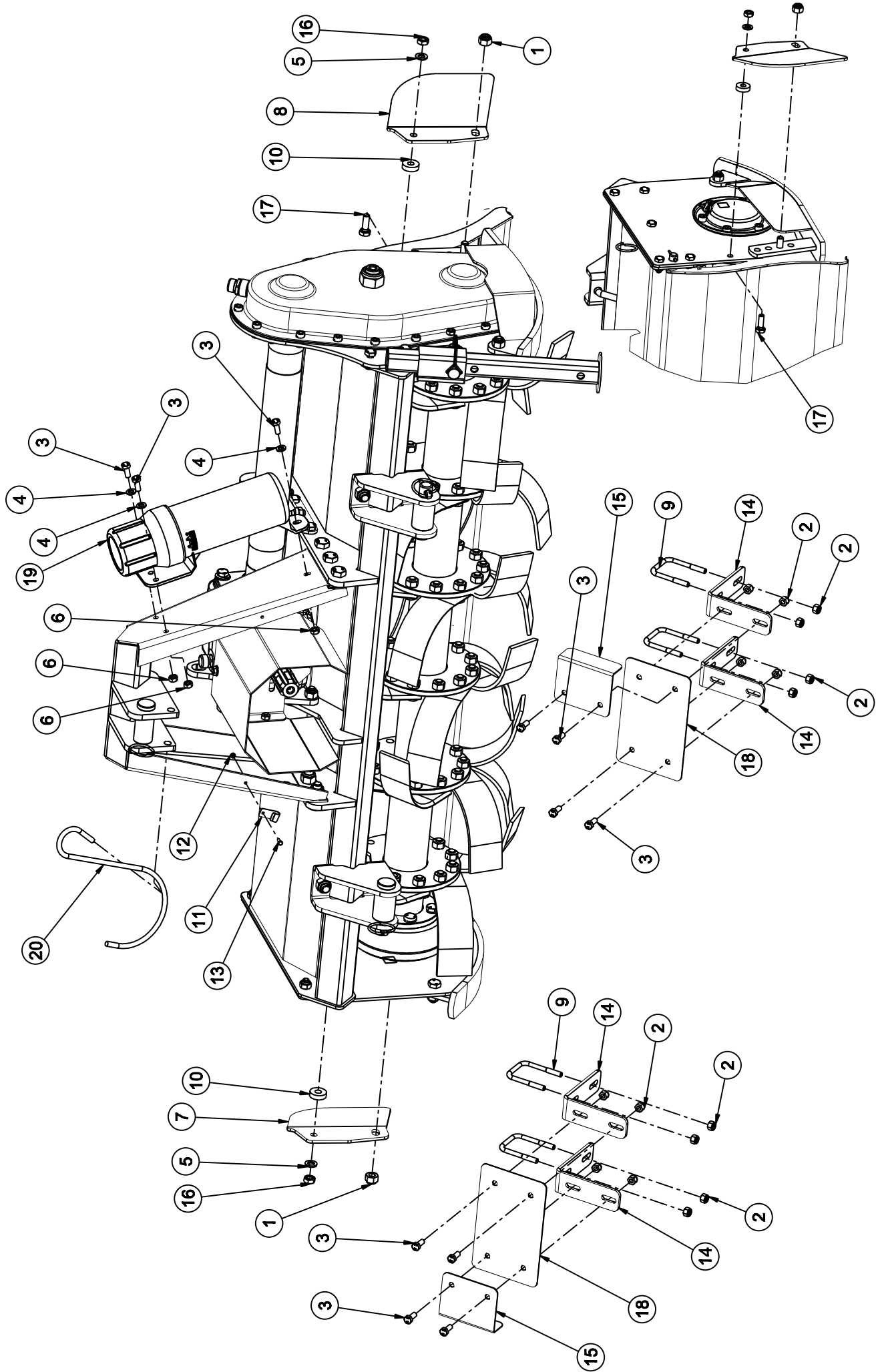

CE KIT ASSEMBLY (UL) SPARE PARTS LIST

ITEM	P/NUMBER	QTY.	PART NAME	REMARKS
1	1209	2	NYLOCK NUT M12X1.75 (DIN-982)	SKID NUT
2	1297	16	NYLOCK NUT M8X1.25 (DIN-982)	For UL-1.2 (CM),1.05 & 1.5
		12		For UL-1.2 (SS)
		8		For UL-0.9
3	8040	11	HEX BOLT M8 X 1.25 X 20	For UL-1.2 (CM),1.05 & 1.5
		9		For UL-1.2 (SS)
		7		For UL-0.9
4	8064	3	PLAIN WASHER 8mm	
5	8078	2	PLAIN WASHER 10mm	
6	8181	3	HEX NUT M8 X 1.25	
7	14183	1	TB GAURD PLATE LH (U-SERIES)	
8	14184	1	TB GAURD PLATE RH (U-SERIES)	
9	14190	4	U-BOLT M8 X 1.25 X 77 X 60 X 28TL	For UL-1.2 (CM),1.05 & 1.5
		3		For UL-1.2 (SS)
		2		For UL-0.9
10	14194	2	SPACER DIA-28 x 11 x 8 MM	
11	23147	1	PLATE,HOOK HOLDING (JUMBO)	
12	23029	1	HEX NUT M4 X 0.75	
13	23029	1	HEX BOLT M4 X 0.75 X 10	
14	4731	4	BRACKET,FRONT BARRIER (REG + & L)	For UL-1.2 (CM)
		2		For UL-0.9
		4		For UL-1.05
		3		For UL-1.2 (SS)
		4		For UL-1.5
15	4741	2	PLATE,END,FRONT BARRIER (REG +)	
16	17272	2	HEX NUT M10 X 1.50 DIN 934	
17	3340	2	HEX BOLT M10 X 1.50 X 30 (8.8) DIN933	
18	14326	2	PLATE,FRONT BARRIER (125 X L=200)	For UL-1.2 (CM)
	14325	2	PLATE,FRONT BARRIER (125 X L=55)	For UL-0.9
	4739	2	PLATE,FRONT BARRIER (L=100) (REG +)	For UL-1.05
	4740	1	PLATE,FRONT BARRIER (L=300) (REG +)	For UL-1.2 (SS)
		2		For UL-1.5
	4781	1	PLATE,FRONT BARRIER (L=75) (REG +)	For UL-1.2 (SS)
19	26030	1	MANUAL BOX COVER 1/2(SMMSD)	
20	14340	1	DRIVELINE HOOK 250MM	